

SUPAANG240

PRODUCT DESCRIPTION



SUPAANG240

SUPAANG240 is an aluminum joist that guarantees the stability and the aesthetic versatility for raised floors installations. SUPAANG240 offers the freedom and flexibility on the tile dimensions, the tile laying patterns and on flooring materials to be used for the raised floor installations.

It can be used in combination with Uptec supports and Uptec Ground (4 mm tabs).

The upper part is equipped with two special rails in which an anti-slip and anti-noise rubber gasket is inserted.

The joist is supplied with the rubber pre-applied, saving installers valuable time, assuring a quick and easy installation.

The lower part includes holes that ensure perfect water outflow, and allow height adjustment during and possibly after installation. In addition, the dented geometry of the holes ensures a secure and stable attachment to the head of the support during installation.

TECHNICAL DRAWINGS

Length: 2,40 m

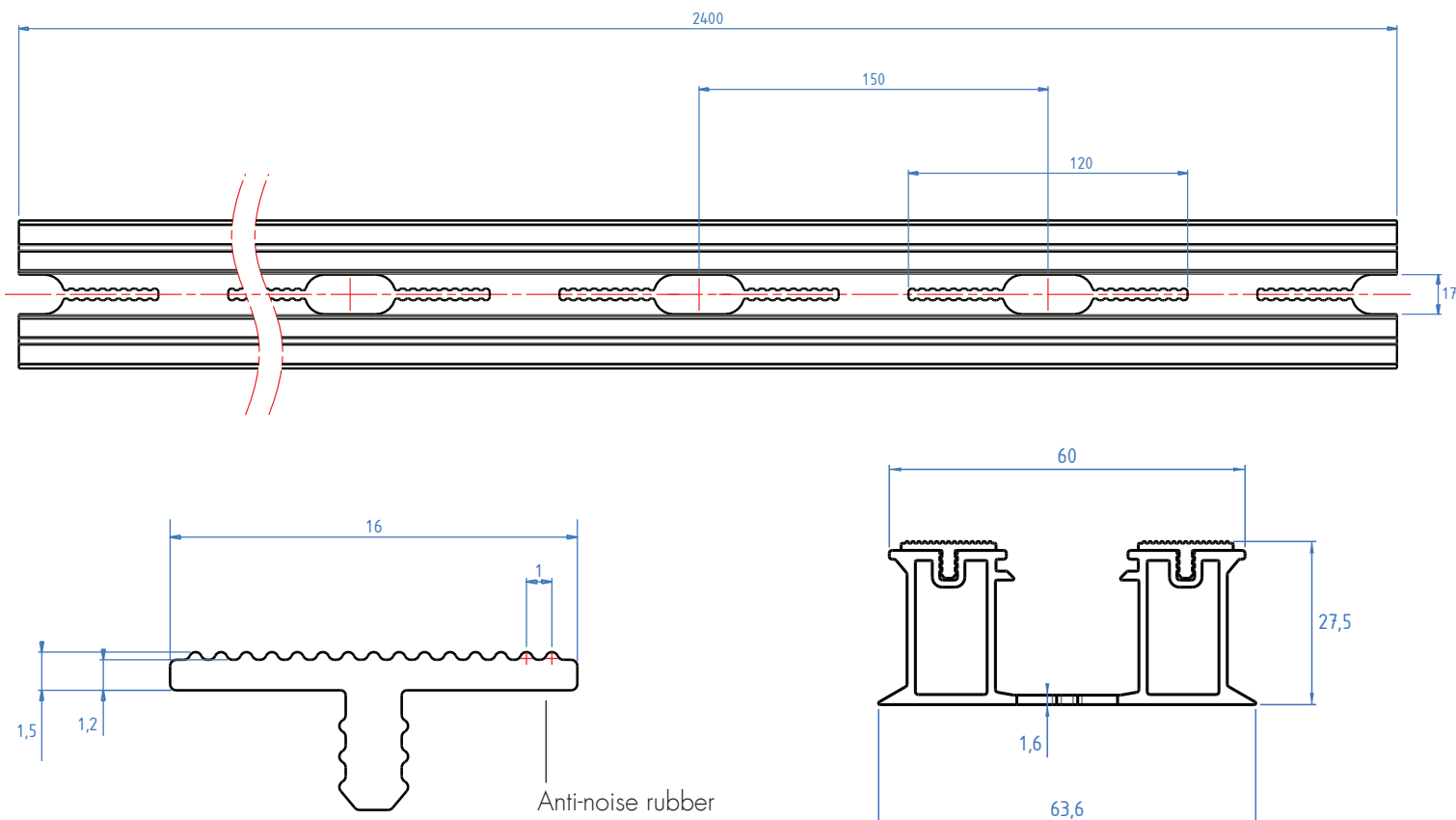

APPLICATION

1. Place and adjust the uptec support to the desired height by choosing the SUPA4 head;
2. Lay the joist on top of the uptec support; embedding it into the 4 mm spacer tabs;
3. Make the final millimeter adjustments with the SUPAK key by taking advantage of the holes in the base of the joist;
4. Place SUPDG spacer or SUPCLIPG depending on the type of covering material to be installed;
5. Lay the flooring.

TECHNICAL FEATURES - SUPAANG240

Art.	Material	Finish	Dimensions	Weight	Environmental impact
SUPAANG240	T6 Aluminum	Natural aluminum	60x27,5x2400	2,226 kg	Recyclable - non-dangerous waste

PACKAGING

Package: 5 pcs

Package weight: 11,130 kg

WARNINGS

SUPAANG240 Uptec and joist supports are designed to support raised floors intended for foot traffic only. They cannot be subjected to vibrating machinery and equipment. This also includes cars, maintenance vehicles and other similar equipment.

ACCESSORIES

- SUPAJG JOINT
- SUPDG
- SUPCLIPG
- SUPACLPT

Profilitec S.p.A.
Via Scotte, 3 - 36033 Isola Vicentina (Vicenza), ITALY
Tel: +39 0444 268311
e-mail: profilitec@profilitec.com (ITA)

Profilitec Corp.
472 Meeting Street, Suite C, No. 301 -
Charleston, SC 29403, USA
Ph: +1 855 290 9591
e-mail: customerservice@profilitec.com

 **profilitec**
positive profile